

7 7 Years
Product Warranty
UK Only

2 2 Years
On-Site Warranty
Main-land UK Only

Alto

Kosnic

06204 ALT30-SCT/MS

Alto LED wall pack 30W IP65 CCT switchable motion ON/OFF

- Diecast aluminium body & polycarbonate diffuser
- Dusk to dawn / microwave sensor option
- IP65
- BESA box fitting points



Overview

The Alto LED Wall Bulkhead is a low maintenance, robust external lighting for commercial buildings.

Suitable for perimeter lighting, pedestrian lighting and vehicle access area lighting. This range has sensor options: dusk to dawn sensor or a microwave presence sensor.

With a metal base and polycarbonate opal diffuser.



IP65



General Information

Ambient Temperature Range (°C)	-20°C to 50°C
IK Rating	IK10
IP Rating	IP65
Nominal Lifetime (h)	50,000 h
Protection Rating	Class I
Installation Area	Internal and External

Technical Summary

Product Code	ALT30-SCT/MS
Input Voltage Supply	220-240Vac 50/60Hz
Default Power	30 W
Driver Code/Part number	Boke
Power Factor	>0.94
Default CCT	4,000 K
Settable Colour Temperatures	3000k, 4000k, 6500k
CRI	≥82
Dimmable	N
Lumens Output Maximum	2,900 lm
Maximum Efficiency	97 lm/W
L80B20 Lifetime (h) @Ta 25 °C	50,000 h
Nominal Lifetime (h)	50,000 h
Weight	1.8Kg
Dimensions (L x W x D) (mm)	309x264x115



Kosnic Lighting



KosnicUK



KosnicLightingUK



KosnicUK

Tel: 01635 523 713

Email: sales@kosnic.com

Kosnic.com

7 Years
Product Warranty
UK Only

2 Years
On-Site Warranty
Main-land UK Only

Alto

Kosnic 

06204 ALT30-SCT/MS

Optional Gear

Product Code	Description	Type
EMDD02	2W standard emergency module for LED DD and bulkhead	Emergency Module
EMDD02/ST	2W self-test emergency module for LED DD and bulkhead	Self-test Emergency Module

Overview

The Alto LED Wall Bulkhead is a low maintenance, robust external lighting for commercial buildings. Suitable for perimeter lighting, pedestrian lighting and vehicle access area lighting. This range has sensor options: dusk to dawn sensor or a microwave presence sensor. With a metal base and polycarbonate opal diffuser.

Settable (Default in Bold)	Variable	
Rated Power (W)	CCT (K)	Total Luminous Flux (lm)
30	3000	2700
30	4000	2900
30	6500	2700



General Information

Ambient Temperature Range (°C)	-20°C to 50°C
IK Rating	IK10
IP Rating	IP65
Nominal Lifetime (h)	50,000 h
Protection Rating	Class I
Installation Area	Internal and External

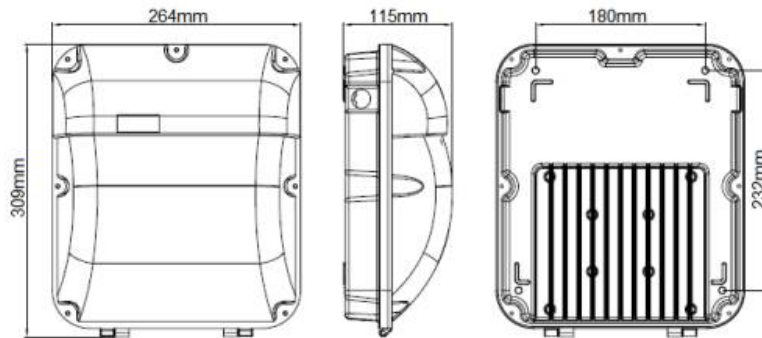

Kosnic Lighting



KosnicUK



KosnicLightingUK



KosnicUK

Tel: 01635 523 713

Email: sales@kosnic.com

Kosnic.com