

**7** 7 Years  
Product Warranty  
UK Only

**2** 2 Years  
On-Site Warranty  
Main-land UK Only



# Echo III

07884 ECH3200-W50

## Echo III LED Circular Highbay IP65 200W 5000K

- High efficiency of 145lm/W
- Diecast aluminium
- Dimmable via a wired 1-10v dimmer switch
- IP65 & vandal resistant (IK10)
- Optional reflectors on all models
- Flicker free



### Overview

The Echo III provides a high efficiency of 145lm/W or a range of wattage options and 1-10v dimming for further control. The IP65 rating and range of shades means the Echo III is suited for a range of areas both internal and external, with optional emergency gear if needed.



IP65



### General Information

Ambient Temperature Range (°C)	-20°C to 50°C
IK Rating	IK10
IP Rating	IP65
Nominal Lifetime (h)	50,000 h
Protection Rating	Class I
Installation Area	Internal and External

### Technical Summary

Product Code	ECH3200-W50
Input Voltage Supply	220-240Vac 50/60Hz
Settable Wattages	100W, 150W, 200W
Driver Code/Part number	Sosen
Power Factor	0.98
Default CCT	5,000 K
SDCM of CCT	<6
CRI	≥82
Dimmable	N
Flicker	<1%
Lumens Output Maximum	30,000 lm
Maximum Efficiency	150 lm/W
Emergency Luminous Flux	900 lm
L80B10 Lifetime (h) @Ta 25 °C	87,000 h
Nominal Lifetime (h)	50,000 h
Weight	2.55Kg
Dimensions (L x W x D) (mm)	164xØ298



Kosnic Lighting



KosnicUK



KosnicLightingUK



KosnicUK

Tel: 01635 523 713

Email: [sales@kosnic.com](mailto:sales@kosnic.com)

[Kosnic.com](http://Kosnic.com)

**7** 7 Years  
Product Warranty  
UK Only

**2** 2 Years  
On-Site Warranty  
Main-land UK Only

# Echo III



07884 ECH3200-W50

## Optional Gear

Product Code	Description	Type
EMHB08/ST	8W self-test Universal Emergency Module for LED high bay	Self-test Emergency Module
EMHB08	8W standard Universal Emergency Module for LED high bay	Emergency Module
EMHB10	10W standard Universal Emergency Module for LED high bay	Emergency Module
EMHB10/ST	10W self-test Universal Emergency Module for LED high bay	Self-test Emergency Module
ECH-RMT	Echo II PIR sensor remote control (for PIR-ZGA)	Remote Control
EMHB10/DA	10W DALI Emergency Module for Kosnic LED high bay	Emergency Module
PIR-ZGA	PIR sensor with Zhaga connector with ON/OFF 0-10V Dimming	PIR Sensor

## Accessories

Product Code	Description	Type
ECH-LID	Echo Translucent bottom enclosure Ø404 x 40 mm for ECH-SHD-PC	Shade
ECH-SHD-AL	Echo aluminium shade for ECHP160, ECHP200, ECH3P200	Shade
ECH-SHD-PC	Echo, PC bell-shaped shade for ECH150, ECH200	Shade

Settable (Default in Bold)		Variable			
CCT (K)	Rated Power (W)	Maximum Current Draw (mA)	Total Luminous Flux (lm)	Power Factor	Light Source Supply
5000	100	460	15000	0.95	195Vdc 480mA
5000	150	690	22500	0.96	195Vdc 720mA
<b>5000</b>	<b>200</b>	<b>890</b>	<b>30000</b>	<b>0.98</b>	<b>195Vdc 920mA</b>

## Overview

The Echo III provides a high efficiency of 145lm/W or a range of wattage options and 1-10v dimming for further control. The IP65 rating and range of shades means the Echo III is suited for a range of areas both internal and external, with optional emergency gear if needed.



IP65



## General Information

Ambient Temperature Range (°C)	-20°C to 50°C
IK Rating	IK10
IP Rating	IP65
Nominal Lifetime (h)	50,000 h
Protection Rating	Class I
Installation Area	Internal and External

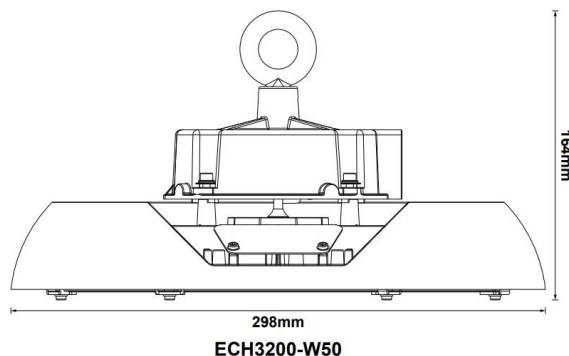

Kosnic Lighting



KosnicUK



KosnicLightingUK



KosnicUK

Tel: 01635 523 713

Email: sales@kosnic.com

Kosnic.com