

**7** 7 Years  
Product Warranty  
UK Only

**2** 2 Years  
On-Site Warranty  
Main-land UK Only



# Nimbo

08133 NIM60-SCT/E

## Nimbo EME circular highbay 15/20/40/60W 3000K/4000K

- High efficiency up to 140lm/W
- Vandal resistant (IK08)
- Diecast aluminium
- Reflector included
- Low glare, UGR < 19 for 15W/20W outputs, UGR<22 for 40W/60W outputs
- Flicker free
- Comes with 0.3m flex.

### Overview

Nimbo High Bay Luminaire is designed for use in general industrial areas, manufacturing, warehousing, leisure facilities and retail environments.

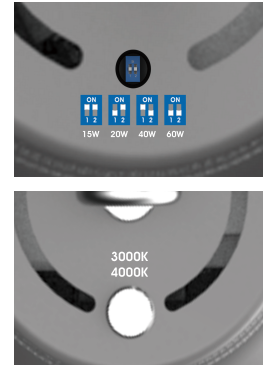

IP20



### General Information

Ambient Temperature Range (°C)	-20°C to 50°C
IK Rating	IK08
IP Rating	IP20
Materials	Housing Aluminium, PC
Nominal Lifetime (h)	50,000 h
Protection Rating	Class I
Installation Area	Internal and External

### Technical Summary

Product Code	NIM60-SCT/E
Input Voltage Supply	220-240Vac 50/60Hz
Settable Wattages	15W, 20W, 40W, 60W
Driver Code/Part number	Sosen
Settable Colour Temperatures	3000k, 4000k
SDCM of CCT	<6
CRI	82
Dimmable	N
Flicker	<1%
Maximum Efficiency	140 lm/W
Maintained Luminous Flux	250 lm
L80B10 Lifetime (h) @Ta 25 °C	54,000 h
Nominal Lifetime (h)	50,000 h
Weight	2kg
Dimensions (L x W x D) (mm)	456xØ330



Kosnic Lighting



KosnicUK



KosnicLightingUK



KosnicUK

Tel: 01635 523 713

Email: sales@kosnic.com

Kosnic.com

**7** 7 Years  
Product Warranty  
UK Only

**2** 2 Years  
On-Site Warranty  
Main-land UK Only

# Nimbo

08133 NIM60-SCT/E

## Accessories

Product Code	Description	Type
BAT20LFP2	LPF battery 6.4V 2000mAh for BEM03	Battery

## Overview

Nimbo High Bay Luminaire is designed for use in general industrial areas, manufacturing, warehousing, leisure facilities and retail environments.

Rated Power (W)	Current (mA)	CCT (k)	Luminous Flux (lm)	UGR	Power Factor
15	87	3000 Warm White	1800	<19	0.75
15	87	4000 Cool White	1950	<19	0.75
20	106	3000 Warm White	2600	<19	0.82
20	106	4000 Cool White	2800	<19	0.825
40	185	3000 Warm White	5200	<22	0.94
40	185	4000 Cool White	5600	<22	0.94
60	275	3000 Warm White	7800	<22	0.95
60	275	4000 Cool White	8400	<22	0.95



**IP20**



## General Information

Ambient Temperature Range (°C)	-20°C to 50°C
IK Rating	IK08
IP Rating	IP20
Materials	Housing Aluminium, PC
Nominal Lifetime (h)	50,000 h
Protection Rating	Class I
Installation Area	Internal and External

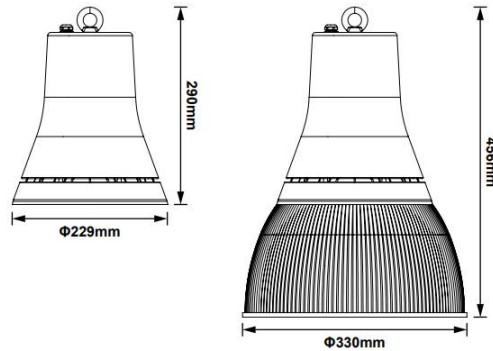

Kosnic Lighting



KosnicUK



KosnicLightingUK



KosnicUK

Tel: 01635 523 713

Email: sales@kosnic.com

Kosnic.com